

Visit www.roadietuner.com/support
for support and FAQs.



Join the Roadie community:

 facebook.com/RoadieTuner

 twitter.com/RoadieTuner

www.roadietuner.com

Made in China



Roadie[®] **BASS**

Product manual
Bedienungsanleitung
Manual del producto
Manuel du produit
製品マニュアル
产品说明书
دليل استخدام المنتج

For the complete user manual, visit:
www.roadietuner.com/support



DOWNLOAD APP



Inside this box

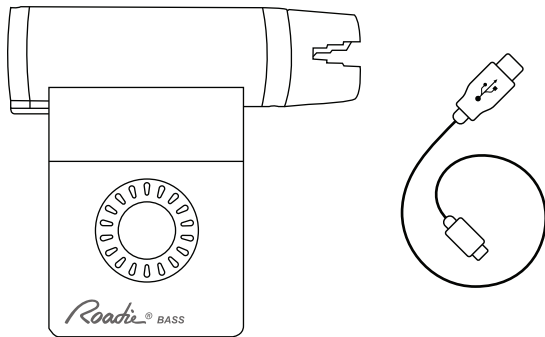

Roadie Bass

USB C charging cable

Turning on and off

EN Press to turn on. Press and hold to turn off.

DE Zum Einschalten drücken. Zum Ausschalten gedrückt halten.

ES Presione para encender. Mantenga presionado para apagar.

FR Appuyer pour allumer. Appuyer et maintenir pour éteindre.

JP 電源ボタンを押して電源を入れます。押し続けると電源が切れます。

CN 按下打开。长按关闭。

AR اضغط لتشغيل الجهاز واضغط بضع ثوانٍ لإطفائه.

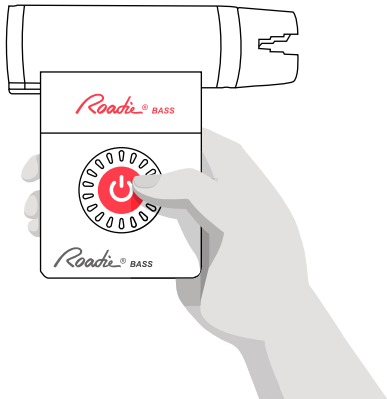

Creating an instrument

EN Select "Add Instrument", choose the type, the number of strings and name it.

DE "Add Instrument" (Instrument hinzufügen) auswählen, den Instrumententyp und die Anzahl der Saiten festlegen und den Namen einfügen.

ES Seleccione "Add Instrument" (Agregar Instrumento), escoge el tipo, el número de cuerdas y dale un nombre.

FR Sélectionner "Add Instrument" (Ajouter un Instrument), choisir le type, le nombre de cordes et insérer un nom.

JP スクリーンの指示に従って、楽器の種類、弦の本数を選び、名前を付けて登録します。

CN 按照说明添加乐器类型，琴弦数量和名称。

AR اختر "Add Instrument" (إضافة آلة)، ثم اختر نوع الآلة، وعدد أوتارها، وسمها.

1. **Add Instrument**
◀ Main Menu
2. **Select Type**
Bass Guitar
Electric Guitar
3. **Number of Strings**
4 Strings
◀ Return
4. **Give it a Name**
1972Bas_
< q r s t u >

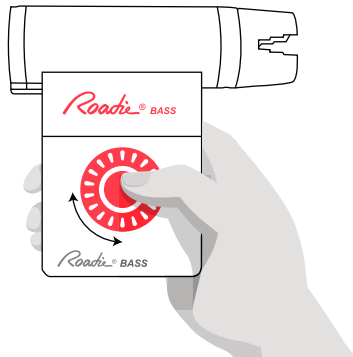

Tuning with Roadie Bass

- EN** Select an instrument from the list.
DE Wähle ein Instrument aus der Liste aus.
ES Seleccione un instrumento de la lista.
FR Sélectionner un instrument dans la liste.
JP リストから楽器を選択します。
CN 从列表中选择一种乐器。
AR اختر آلة من اللائحة.

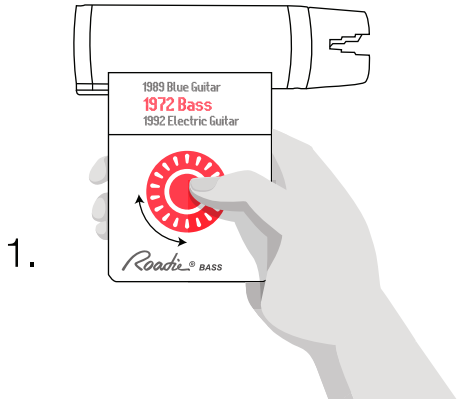

- EN** Place Roadie on the peg starting with the lowest note.
DE Setze die Motorkurbel des Roadie an den Stimmwirbel (Mechanik), beginne mit der Saite mit dem tiefsten Ton.
ES Coloque el conector de Roadie en la clavija de afinación (cabezal) más baja.
FR Placer le connecteur de Roadie sur la cheville d'accordage de votre instrument commençant par la note la plus basse.
JP スクリーンに従って一番低い弦のチューニングペグ(マシンヘッド)にRoadie(ローデ) Bassのペグコネクタを合わせます。
CN 根据屏幕上显示的音符，把Roadie Bass插在弦轴上，从最低音的琴弦开始调音。
AR ضع جهاز رودي على مفتاح الوتر مبتدئاً بأدنى وتر.

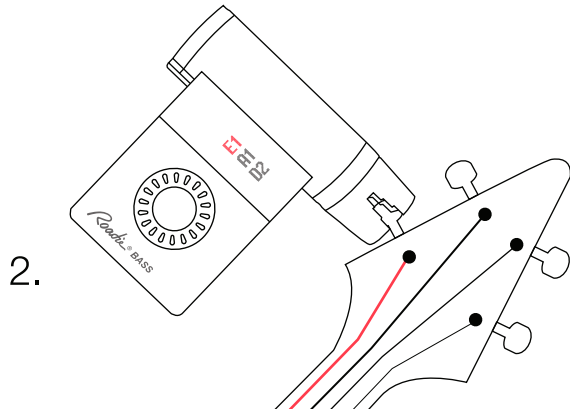

- EN** Pluck the string.
DE Spiele die Saite.
ES Puntee la cuerda.
FR Pincer la corde.
JP 弦をはじき鳴らします。
CN 拨动琴弦。
AR انقر الوتر.

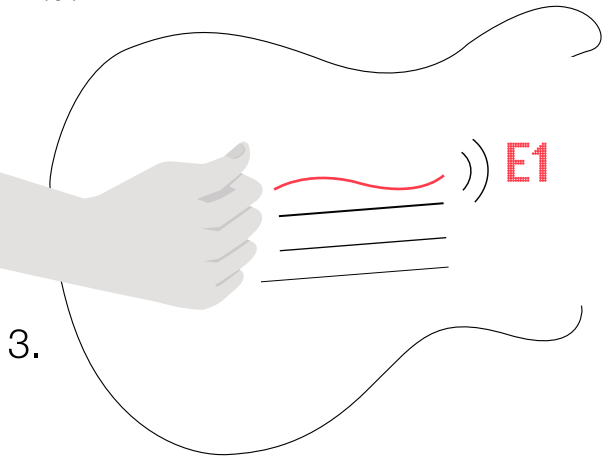

- EN** When the string is tuned, Roadie will vibrate, flash a light and beep. Move on to the next string.
DE Wenn die Saite gestimmt ist, vibriert und piept Roadie und ein Licht leuchtet auf. Fahre fort mit der nächsten Saite.
ES Cuando la cuerda esta afinada, Roadie vibrará, encenderá una luz y hará un sonido. Pase a la siguiente cuerda.
FR Quand la corde est accordée, Roadie vibre, clignote et émet un son. Passer à la corde suivante.
JP 弦のチューニングが完了すると、Roadieが振動し、ライトが点滅し、ビープ音が鳴ります。次の文字列に移動します。
CN 当琴弦被调音时，Roadie会振动，发出哔哔声。移到下一个字符串。
AR عندما تنتهي عملية ضبط الوتر، يهتز جهاز رودي، و يضيء، و يصدر صوتاً. انتقل الى الوتر التالي.

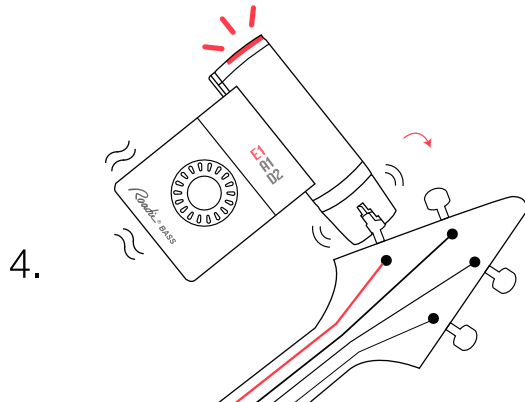

Re-stringing with Roadie Bass

- EN** Return to the main menu and select Wind/Unwind.
DE Um eine Saite auszutauschen, wähle im Hauptmenü "Wind/Unwind" (Aufwickeln/Abwickeln).
ES Regresa al menú principal y selecciona "Wind/Unwind" (Ajustar/Soltar).
FR Retourner au menu principal et sélectionner "Wind/Unwind" (Enrouler/Dérouler).
JP 弦を交換する時はメインメニューでWind/Unwindを選択します。
CN 在菜单中选择 (卷弦/放弦)
AR عد إلى القائمة الرئيسية واختار "Wind/Unwind" (لف\فك).

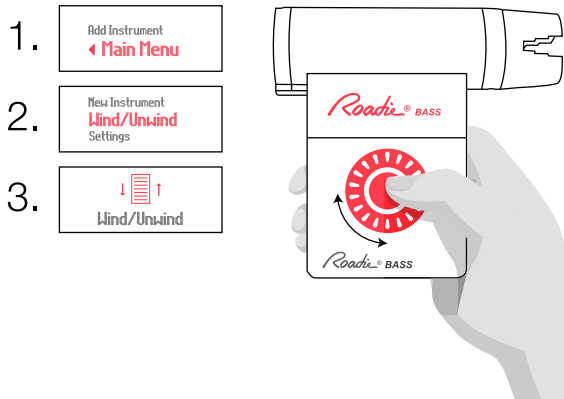

- EN** Turn the wheel in the direction you would like to rotate the peg.
DE Drehe das Navigationsrad in die Richtung, in welche sich die Motorkurbel drehen soll.
ES Gire la rueda de navegación en la dirección que desea girar el conector de clavija.
FR Tourner la molette de navigation pour faire pivoter le connecteur dans la direction souhaitée.
JP ペグを回転させたい方向にホイールを回します。巻き上げる時はWind、緩める時はUnwind方向です。
CN 根据您想要的方向旋转转盘，从而旋转弦轴。
AR أدر القرص في الاتجاه الذي ترغب ببرم المفتاح إليه.

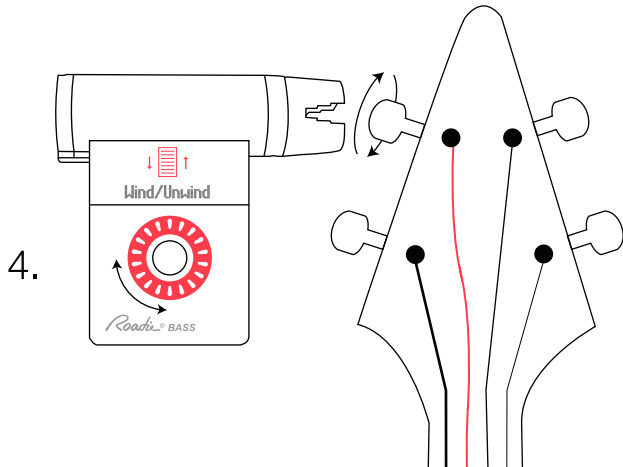

Power and recharging

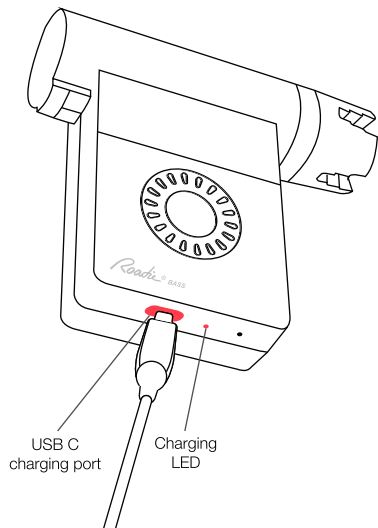

Troubleshooting

- EN** Insert a pin into the reset pin hole.
- DE** Zur Störungsbehebung stecke einen Stift in das Reset-Loch.
- ES** Inserte un alfiler en el agujero de reinicio.
- FR** Insérer une épingle dans le trou de réinitialisation.
- JP** リセットピンホールにピンを挿入します。
- CN** 将针插入重启针孔。
- AR** أدخل دبوساً في ثقب الإعادة إلى الوضع الأولي.

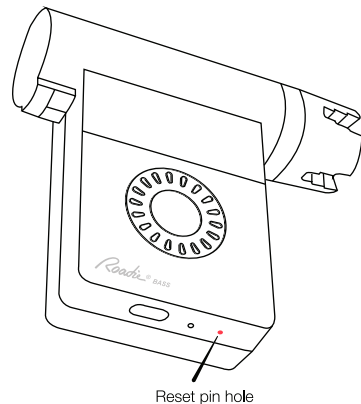

Compliance

This device complies with Industry Canada's licence-exempt RSSs. Operation is subject to the following two conditions:

- (1) This device may not cause interference; and
- (2) This device must accept any interference, including interference that may cause undesired operation of the device.

This device complies with Part 15 of the FCC Rules. Operation is subject to the following two conditions:

1. This device may not cause harmful interference.
2. This device must accept any interference received, including interference that may cause undesired operation.

Note

This equipment has been tested and found to comply with the limits for a Class B digital device, pursuant to part 15 of the FCC Rules. These limits are designed to provide reasonable protection against harmful interference in a residential installation. This equipment generates, uses and can radiate radio frequency energy and, if not installed and used in accordance with the instructions, may cause harmful interference to radio communications. However, there is no guarantee that interference will not occur in a particular installation. If this equipment does cause harmful interference to radio or television reception, which can be determined by turning the equipment off and on, the user is encouraged to try to correct the interference by one or more of the following measures:

- Reorient or relocate the receiving antenna.
- Increase the separation between the equipment and receiver.
- Connect the equipment into an outlet on a circuit different from that to which the receiver is connected.
- Consult the dealer or an experienced radio/TV technician for help.

Caution

Any changes or modifications not expressly approved by the party responsible for compliance could void the user's authority to operate this equipment.

FCC radiation exposure statement

This equipment complies with FCC radiation exposure limits set forth for an uncontrolled environment.

Safety instructions

Please read these instructions, keep them and follow them.

- Do not tamper with your tuner.
- Do not attempt to disassemble or open your tuner. Substances contained in this product and/or its battery may damage the environment and/or human health if handled and disposed of improperly.
- Do not expose your tuner to extremely high or low temperatures.
- Do not leave your tuner in direct sunlight for an extended period of time.
- Do not leave your tuner near open flames.
- Do not dispose of your tuner in a fire. The battery could explode.
- Do not use abrasive cleaners to clean your tuner.
- Do not place your tuner in a dishwasher, washing machine or dryer.
- Regardless of what reasons cause unit damage, please ask for the maintenance personnel to repair it.

Warning

The battery shall not be exposed to excessive heat such as sunshine, fire or the like.

Caution

Danger of explosion if battery is incorrectly replaced. Replace only with the same or equivalent type.



Correct disposal of this product.

This marking indicates that this product should not be disposed with other household wastes throughout the EU. To prevent possible harm to the environment or human health from uncontrolled waste disposal, recycle it responsibly to promote the sustainable reuse of material resources. To return your used device, please use the return and collection systems or contact the retailer where the product was purchased. They can take this product for environmental safe recycling. Operating temperature 32-104°F (0-40°C).

Conformité électronique

Cet appareil est conforme aux CNR exemptes de licence d'Industrie Canada. Son fonctionnement est soumis aux deux conditions suivantes:

- (1) Ce dispositif ne peut causer d'interférences; et
- (2) Ce dispositif doit accepter toute interférence, y compris les interférences qui peuvent causer un mauvais fonctionnement de l'appareil.

Disclaimer

This manual describes the version of Roadie Bass as of February 2018. Although Band Industries has made every effort to ensure that the information contained in it was correct at publish time, it does not assume and hereby disclaim any liability to any party for any loss, damage or disruption caused by errors or omissions, whether such errors or omissions result from negligence, accident or any other cause. The information in this Product Manual is subject to change without notice. Band Industries makes no representations or warranties with respect to the content hereof and specifically disclaims any implied warranties of merchantability or fitness for any particular purpose. Band Industries reserves the right to revise this publication and to make changes from time to time in the content hereof without obligation of Band Industries to notify any person of such revision or changes.

Copyright

This publication, including all photographs, illustrations and software, is protected under international copyright laws, with all rights reserved. Neither this Product Manual, nor any of the material contained herein, may be reproduced without written consent of Band Industries.

Trademark recognition

Band Industries, the Band Industries logo, Roadie, and Roadie Tuner are trademarks and/or registered trademarks of Band Industries, Inc. in the U.S., E.U. and other countries.

One year limited warranty

Band Industries warrants the included hardware product and accessories against defects in materials and workmanship for one year from the date of original retail purchase. Band Industries does not warrant against normal wear and tear, nor damage caused by accident or abuse.

To obtain service, please email us at

support@bandindustries.com